

EUROTEC SRL-COLGED DIVISION. All rights reserved. Copy, reproduction or use of any part of this drawing is strictly prohibited without prior written permission.

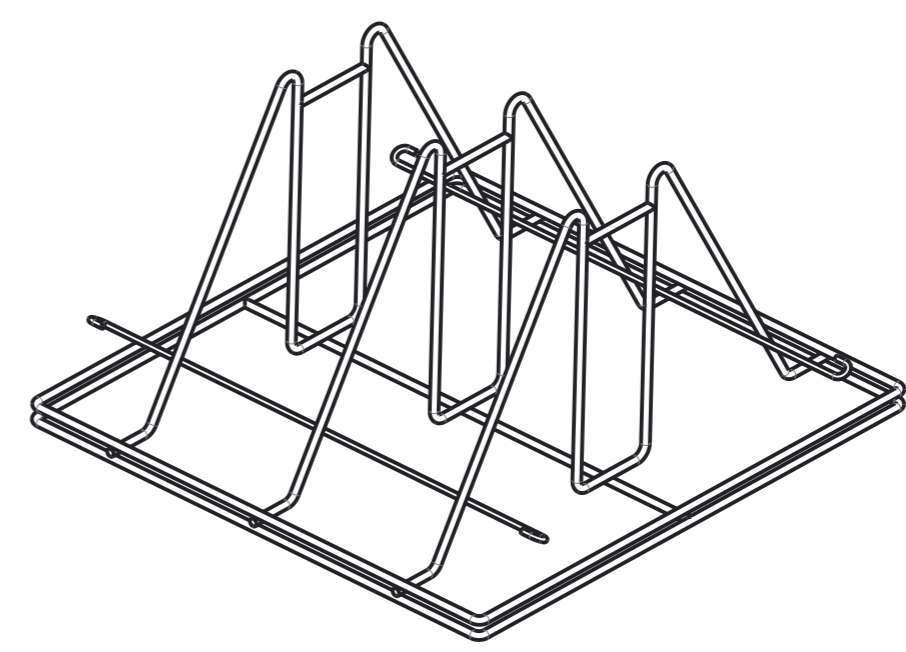
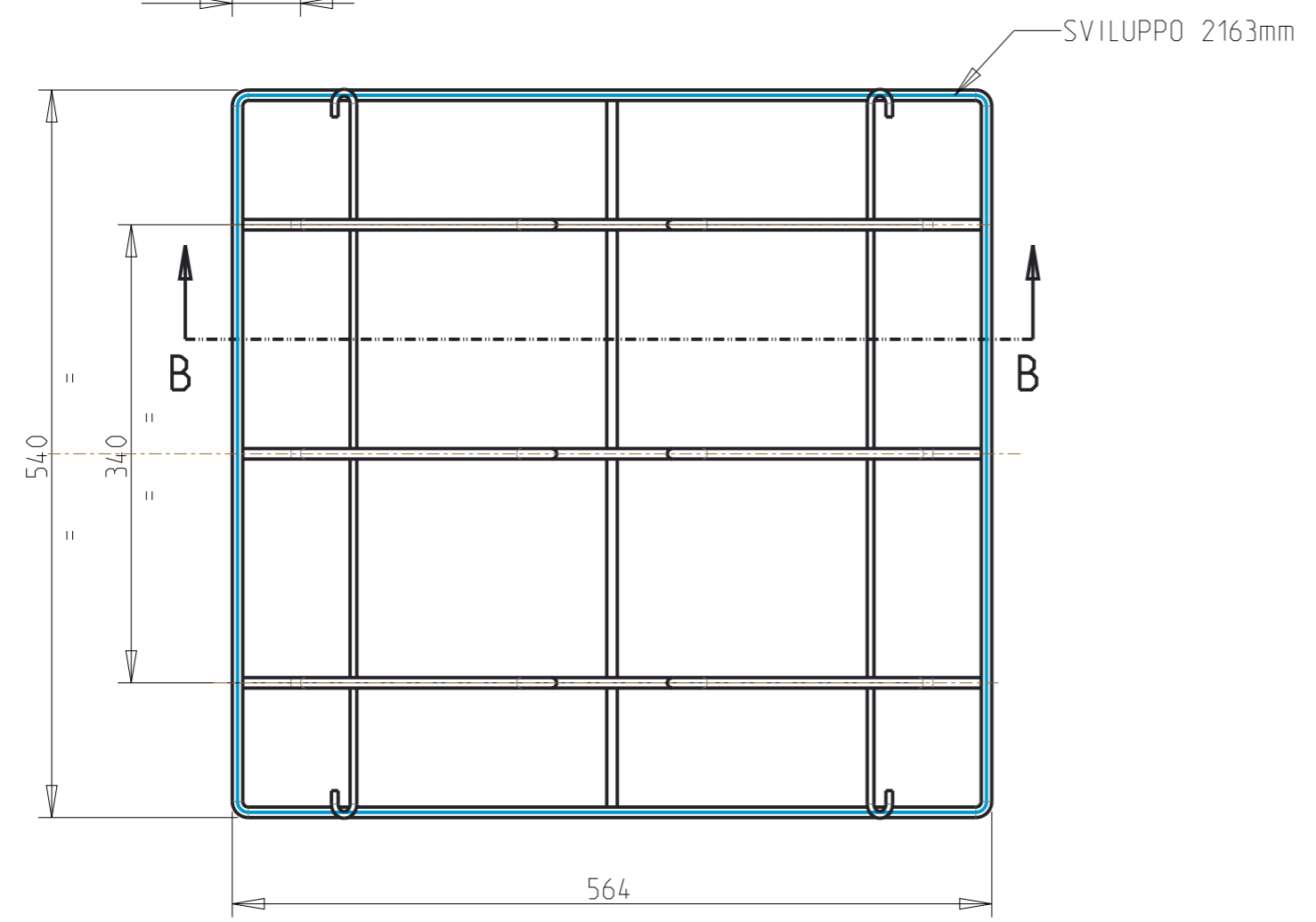
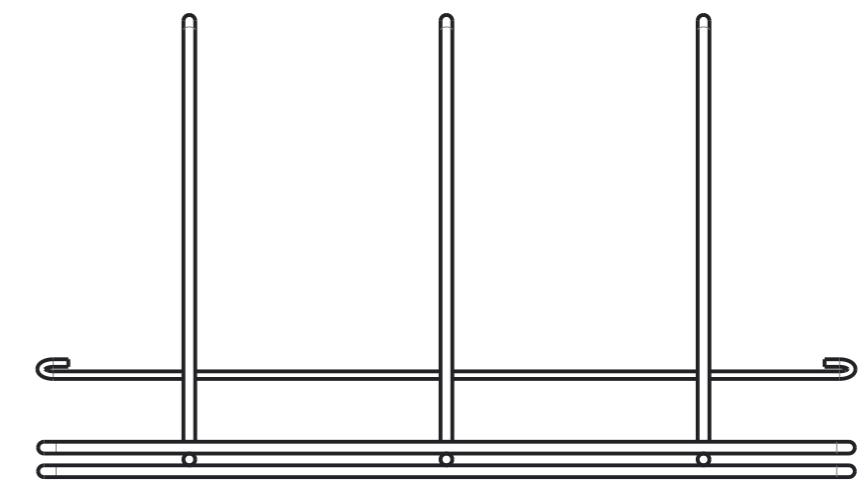
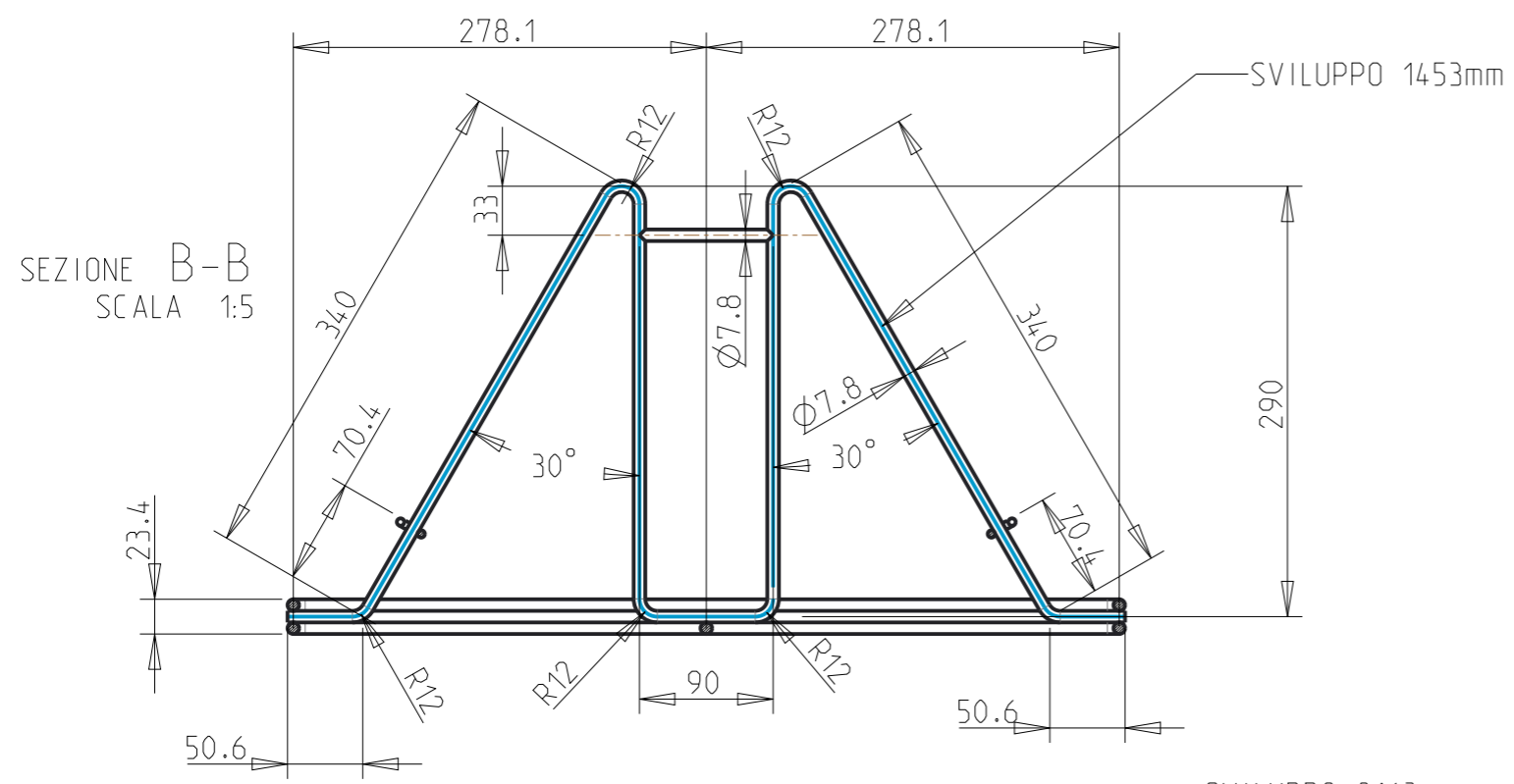

	ATTENTION : General tollerances in according with EN 22768-1/2 class "m" Excepted where otherwise noted Maximal rugosity = 0.1 mm. <input type="checkbox"/> = CRITICAL DIMENSIONS	SUFFIX IDENTIFICATION OF STATE PART (code follows)	
		STATE LASER CUTTED OR PUNCHED MOULDED PARTIALLY BENDED (only bends with "*") BENDED	PZ ST PGI PG
Destinated to : LP		Object : INSERTO PER VASCHETTE GELATO	Weight (kg): 0.003
Designed by : M. Pieri	Date : 10.12.2020	Material : FILO INOX AISI 304	Scale : 1 of 1
Checked by : -	Date : -	Mould : -	Sheet format : A3
Validated by : -	Date : -	Tool : -	Drawing number : 67909
Mod. : -	Last modify description : -	Replace : -	Mod. : 00